

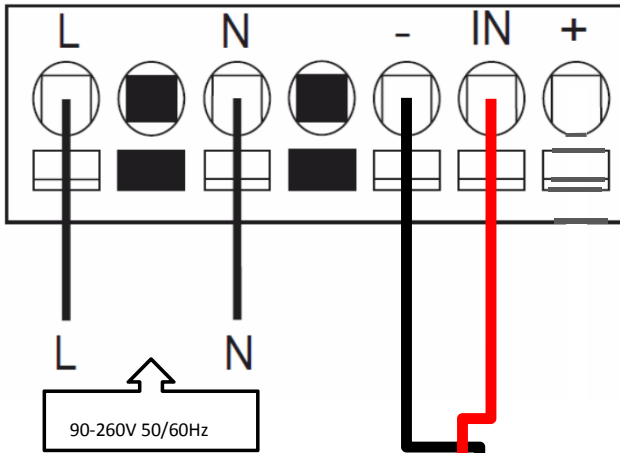

Aansluitschema nummer: 24

Onderwerp:

TD 160/100 ECOWATT buisventilator i.c.m. CO₂-sensor en 24V voeding t.b.v. CO₂-sensor



Aansluitschema **buisventilator**:

Aansluitschema **SCO2-A en SCO2-AD**:

GND (2)	massa
CO ₂ (5)	analoog signaal uit (0-10VDC/0-20 mA)
GND (6)	massa
V+ (1)	voeding + / DC - AC

SCO2-A / SCO2-AD

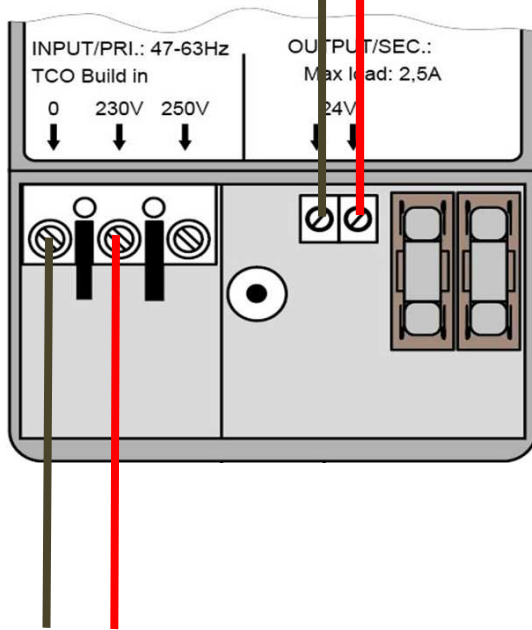

Aansluitschema **TRAFO60**:

230V 50Hz